

Building FaithChests®

Thank you for your interest in the FaithChest® program. This is a wonderful ministry you are beginning and the gift of a FaithChest® will be a life long treasure for each child and his or her family. We all have different God given talents or skills and using your hands to create this gift is a powerful way to use your gifts.

Several years ago Dr. Dick Hardel visited Ezekiel Lutheran and introduced the program, "Child in Our Hands" from Vibrant Faith Ministries formerly The Youth and Family Institute. My wife came home after the meeting and after explaining the program said, can you build something like this? The rest is history. The drawings were created from my sketch by a friend using AutoCAD and are formatted in a PDF format. There are also a number of pictures illustrating the material and steps I use in the FaithChest® build.

FaithChest® is a registered trademark of Vibrant Faith Ministries – www.vibrantfaith.org

Begin by printing a set of drawings and then do a slideshow of all the pictures. These drawing are a starting point for you and only your creativity will limit your design. For material I use edge-glued pine. It can be purchased in a variety of widths and length and I find this to be both cost effective and times saving. If you want to use other materials select a wood and edge glue the boards into suitable size panels. Plywood can also be used but an edge banding should be applied to cover the layers. After I have cut the blanks to rough sizes I fill all knots and/or voids with a wood filler and rough sand. After cutting the blanks to finish size I finish sand the inside surfaces and assemble with glue and brad nail. When the panels have been cut to size and can not start the assembly, stack and weight them flat until assembly. I like to use 3/4" Crown Staples to attach the bottom to the box.

For hardware I use a 2" Stanley Narrow Hinge. They come in wide, middle and narrow sizes. I also use a Stanley Lid Support. This will keep the children from getting their fingers slammed between the lid and the box. Being right handed I find the left hand lid support is easier to install. You will note I use jigs for locating drilled holes and handle assembly. I also have templates to route the edge detail on the legs. A homemade panel cutter makes an easy job out of cutting the panels ends to 45 degrees and to length. After assembly I fill all nail holes and finish sand. I build in sets of 5 and find this to be a convenient number to work with.

Finishing can be done with a stain of choice and completed with several coats of sealer. If you stain pine it is a good idea to use a wood conditioner first to prevent uneven stain on the soft wood. I use a shortcut method with a mixture of 1/4 to 1/3 stain and the rest Tung Oil. Wood conditioner is not needed for this process. Finish with 2 or 3 more coats of Tung Oil with very light sanding between coats.

At the child's baptism, in addition to the baptism certificate and candle, Ezekiel includes a child's first bible and an engraved baptism medallion with the child's name and baptism date. If your church has a Thrivent Congregational Coordinator they can order medallions from Thrivent Financial for Lutherans at no charge.

Thank you again for your interest and many and rich blessing for you and your new ministry. If you have any question, contact me at any time. Feel free pass this information to others.

Jan Gunderson
715 425-9472
JGGunderson@msn.com

June 2006

Faith Chest
Ezekiel Lutheran Church
River Falls, WI
by: Jan Gunderson

matl: 24 feet 1"x 6" #2 or better pine
1/4" plywood (bottom)
(2) 2" brass hinge
(1) brass friction lid support
4 feet 1"x 1" outside corner (pine)
8 feet 1" lattice (pine)

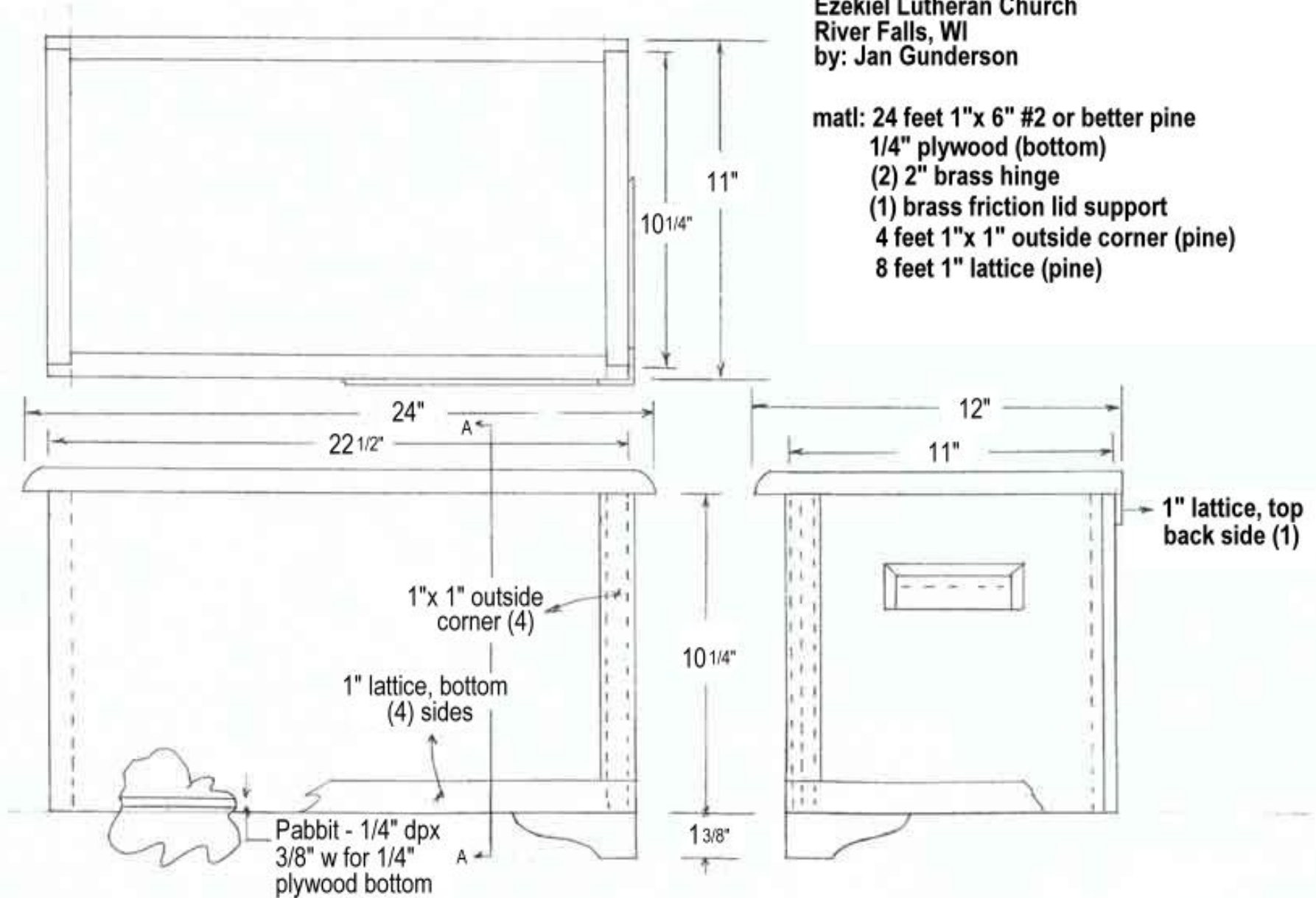

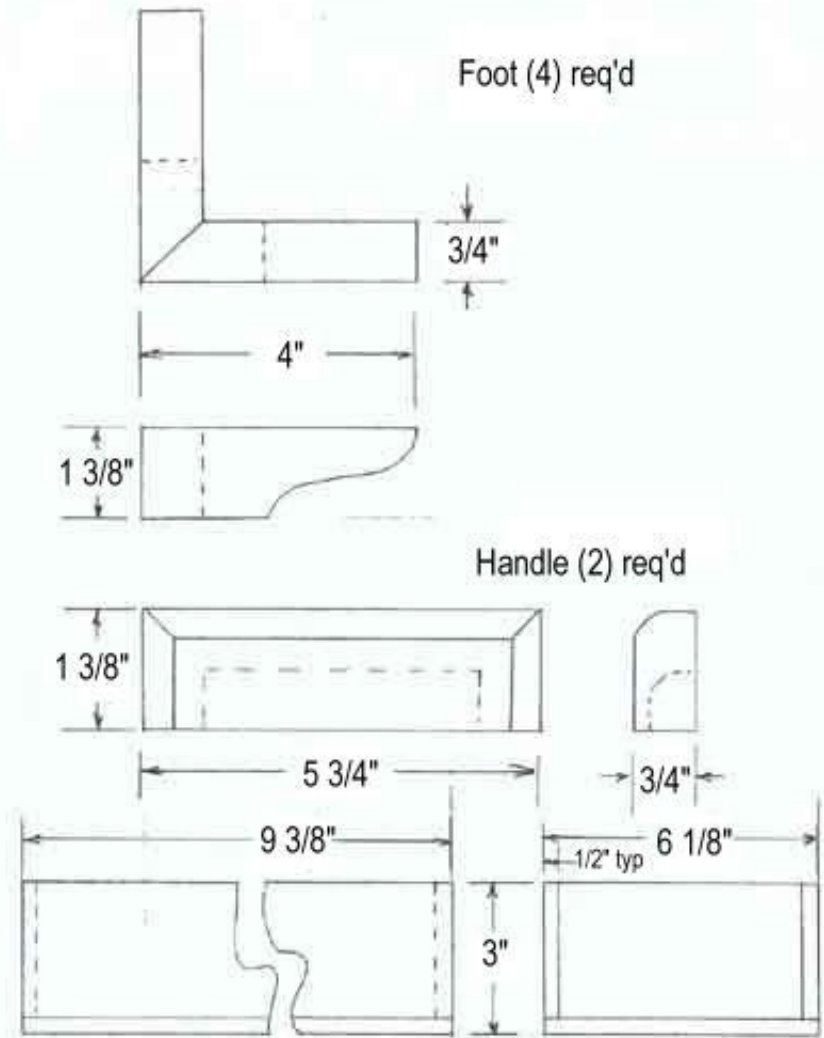
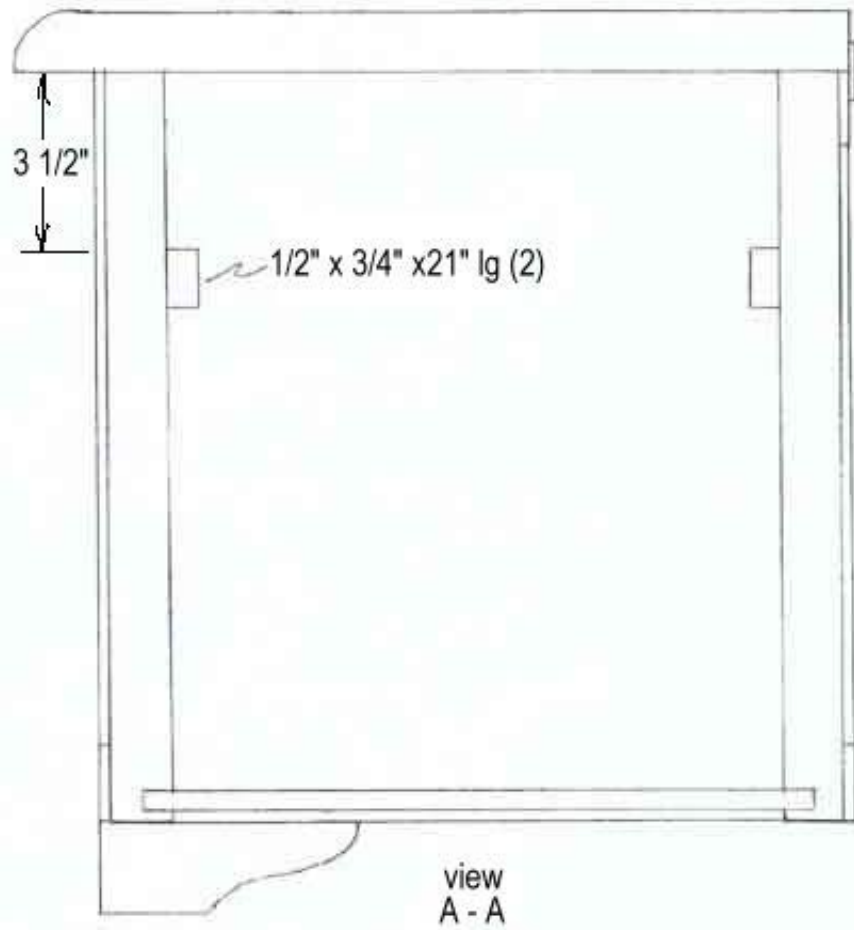

Inner box - 1/2" Pine/Baltic Birch